



BLIK SEPARATION: Vibrating tables, Trommels

BLIK SEPARATORS are 2 types: vibrating tables and Trommels.

Alone - or in output of a crusher, they automatically sort the material into two or more phases of different granulations, without any manutentions

Robust, modular, adaptable, they are outstanding productivity tools. They are ideal for the separation of most materials

Vibrating table BLIK Serie TIBY 1500-500, 2 motors



Blik crusher B600 and vibrating table BLIK in output

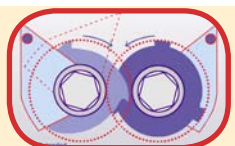
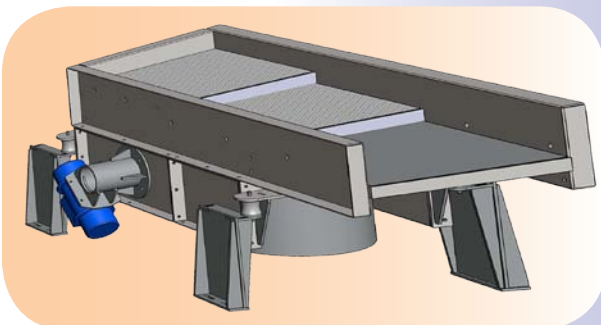
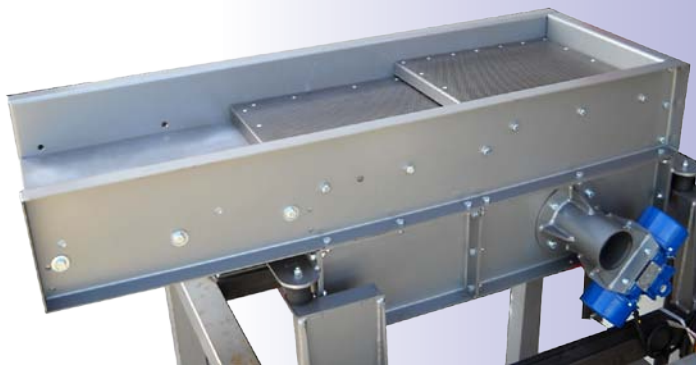

BLIK

BLIK - Waste Recovery and Processing Equipment



www.blik.fr

Z.I. de Chenet
91490 MILLY-LA-FORET
E.mail: blik@blik.fr

telephone:
33 (0)1 64 98 79 79
fax:
33 (0)1 64 98 79 78

Vibrating table BLIK Serie TIBY 1500-500, 2 motors

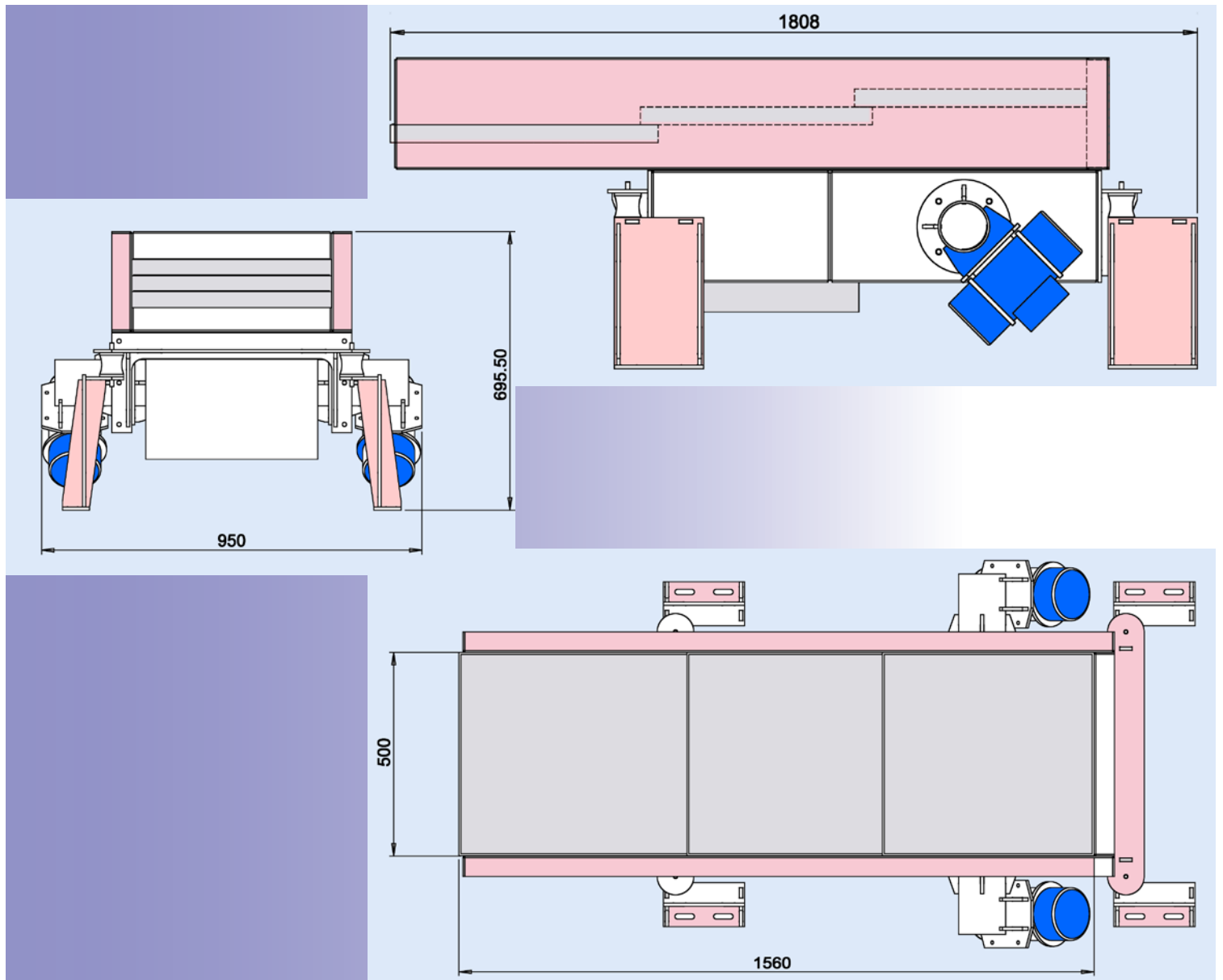

VIBRATING TABLE BLIK TIBY 1500-500 : Width 500 mm lenght 1500 mm

Effective width of the screen segment	420 mm
Total length	1550 mm
effective lenght of thre screen	880 mm
Interchangeable screen segments	
Diameter of screen holes	according to thr tries
Motors	2 moteurs à balourd à masse réglable
Angle of motors	adjustable
Power motors	three phases 200W / 400V / 50Hz
Outside dimensions (mm) without stand support width x depth x Height	1808 x 950 x 696 mm
Debit	Varies depending on product flow to be treated
refusal sorting falls at the end of screen	
Weight (KG)	approx 450
“CE” certified - 1 year guarantee (*) –	Subject to technical and optical modifications
Options	Feed hopper; chassis standard support

TROMMELS (Rotary screen) BLIK Series TR 800-3 et TR 1600-4

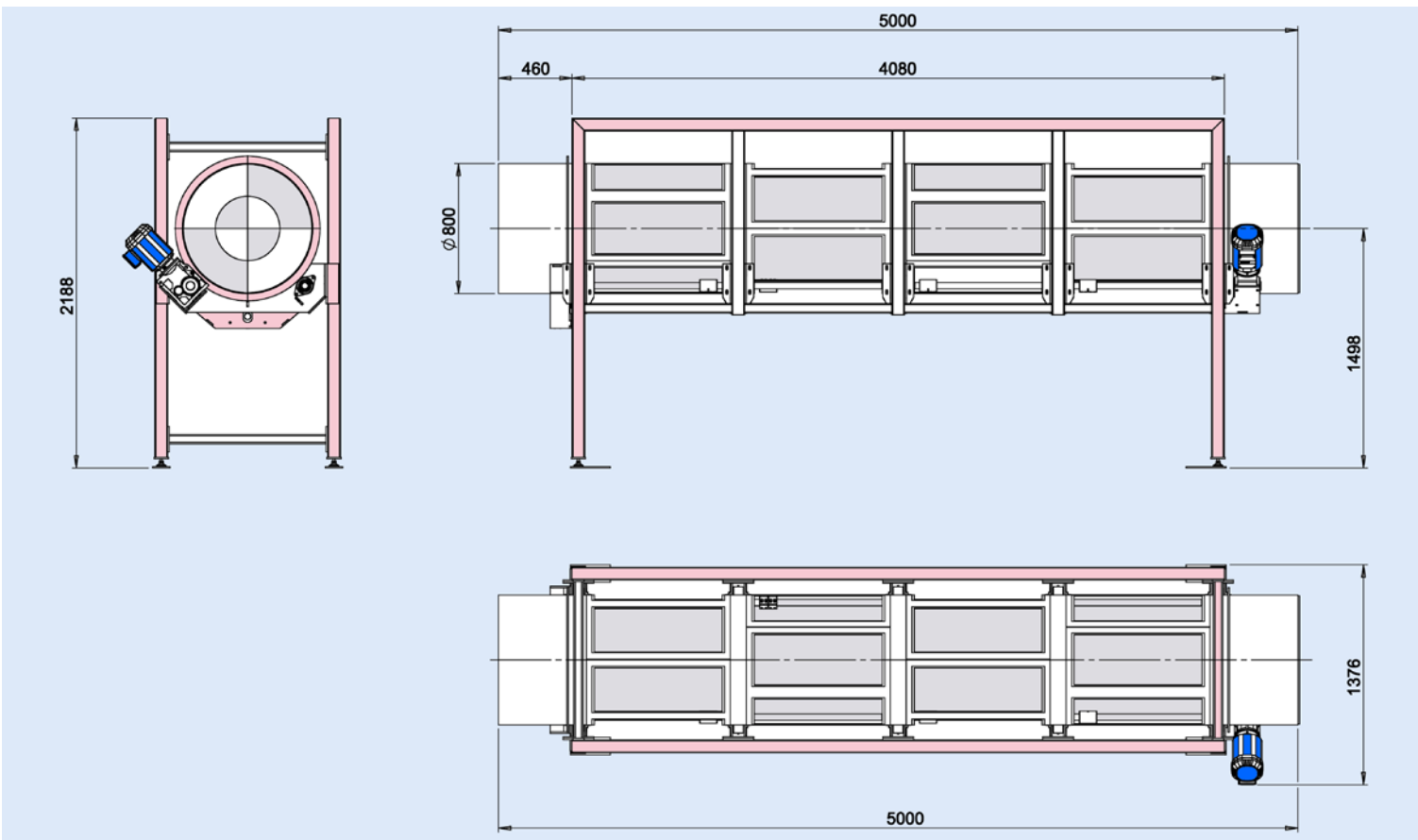
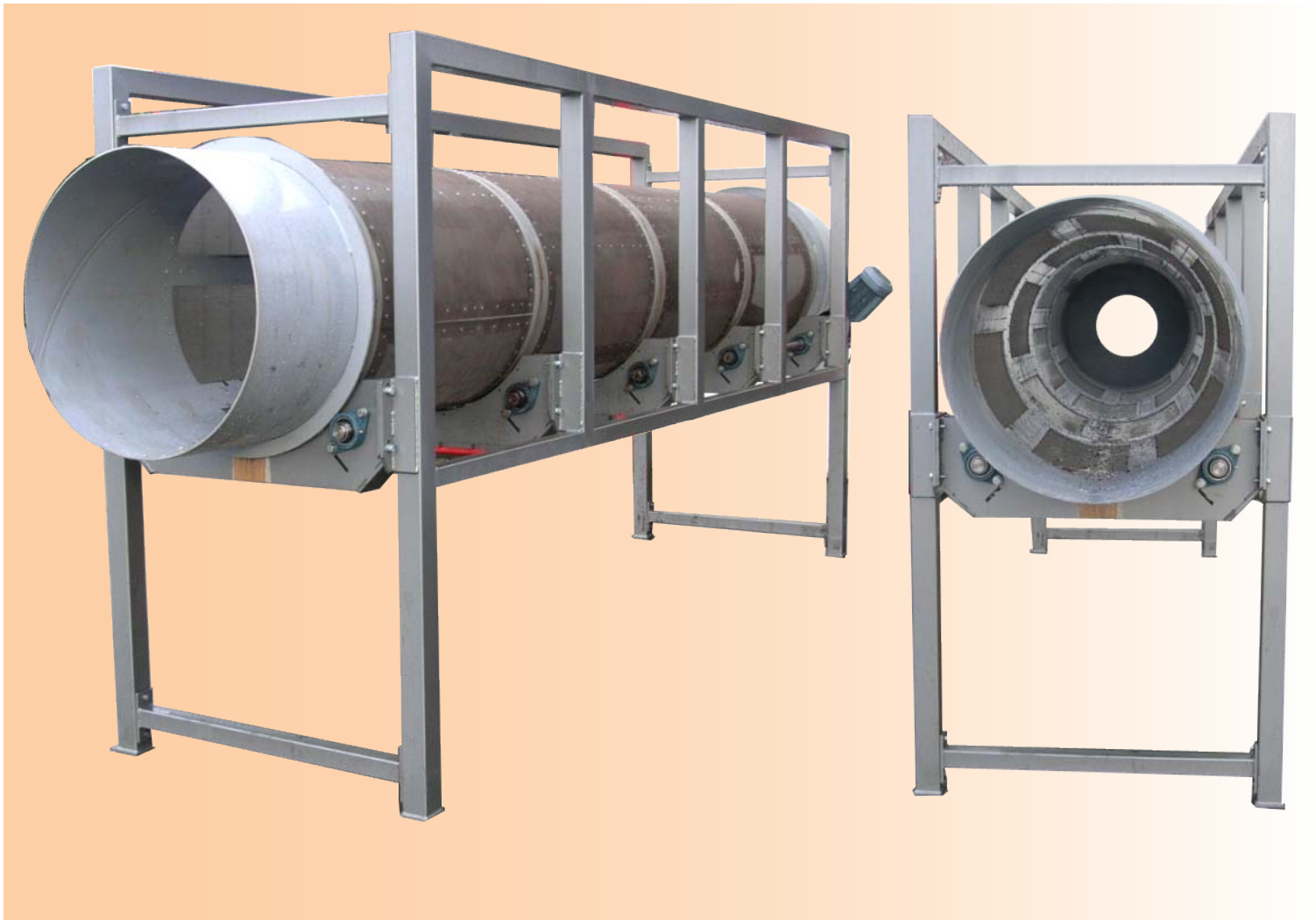

TTROMMELS (Rotary screen) BLIK Series TR 800-3 et TR 1600-4

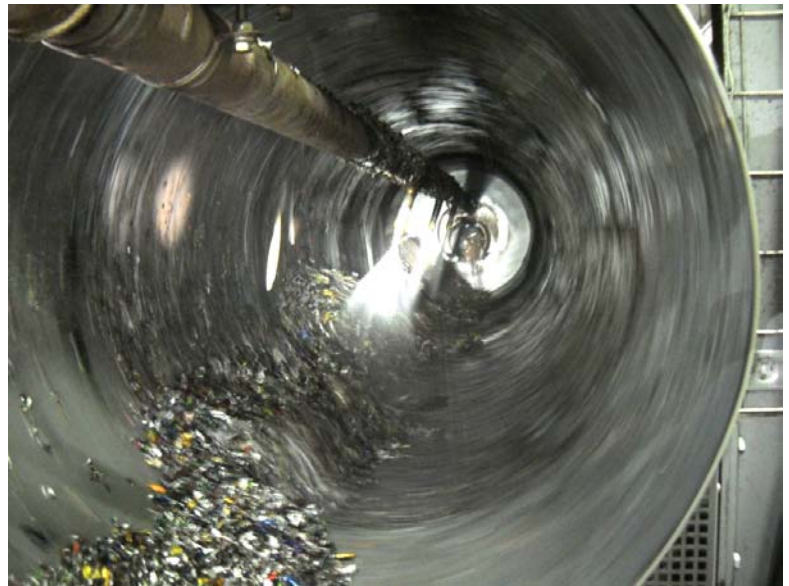
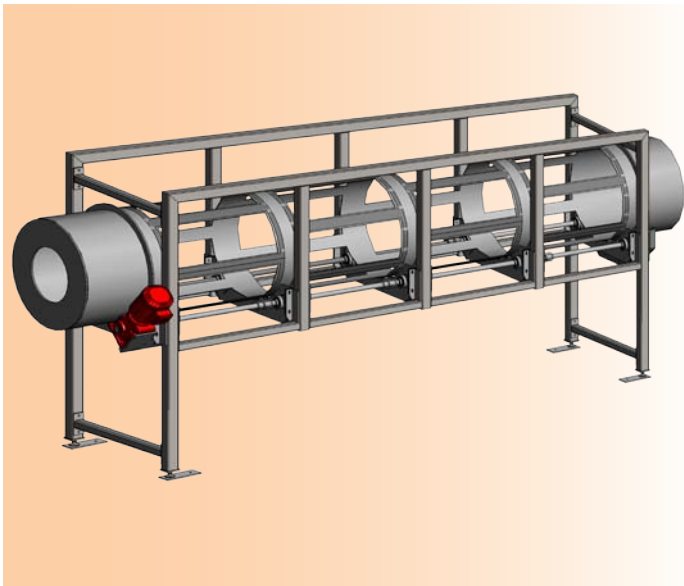

TROMMEL (Rotative screen) BLIK TR 800-3- diameter 800 mm length 3000 mm

diameter of the rotary screen	800 mm
Total length	3000 mm
effective length of the screen	2700 mm
Interchangeable screen segments	
Diameter of screen holes	
Rotating brushes for cleaning the upper parts of the screen segments	according to the tries
Rotation speed	15 TPM - ajustable par variateur
Power motors	three phases 3 kw / 400 V / 50 Hz / 4 A
Outside dimensions (mm) without stand support width x depth x Height	4160 x 1200 x 1900 mm
Debit	Varies depending on product flow to be treated
refusal sorting falls at the end of screen	
Weight (KG)	450
"CE" certified - 1 year guarantee (*)	

TROMMEL (Rotative screen) BLIK TR 1600-4- diameter 1600 mm length 4000 mm

diameter of the rotary screen	1600 mm
Total length	4000 mm
effective length of the screen	3600 mm
Interchangeable screen segments	
Diameter of screen holes	
Rotating brushes for cleaning the upper parts of the screen segments	according to the tries
Rotation speed	15 TPM - ajustable par variateur
Power motors	three phases 3 kw / 400 V / 50 Hz / 4 A
Outside dimensions (mm) without stand support width x depth x Height	5160 x 1200 x 1900 mm
Debit	Varies depending on product flow to be treated
refusal sorting falls at the end of screen	
Weight (KG)	600
"CE" certified - 1 year guarantee (*)	