

BLiK «DISCOFUT» PRESS

Compaction of contaminated waste (inside the barrels)

This material can compact inside the barrels, with or without paperboard-guide (discofut type)

The pressure of compaction is optimized to obtain a good reduction of volume without damaging or marking the barrel.

The unit profits from a sufficient containment so that, connected to a system of aspiration and processing of the air (not provided), the operators can use this hardware under good conditions of security.

This material designed by BLIK is exclusively intended for compaction of contaminated waste.

This formula proves more effective and more economic than the modification of an

existing model,

in particular from the point of view of the ergonomics and facility of loading of waste.

This material is of course CE certified



BLiK

BLIK - Waste Recovery and Processing Equipment



www.blik.fr

Z.I. de Chenet
91490 MILLY-LA-FORET
E.mail: blik@blik.fr

telephone:
33 (0)1 64 98 79 79
fax:
33 (0)1 64 98 79 78

BLiK «DISCOFUT» PRESS

Compaction of contaminated waste (inside the barrels) continuation

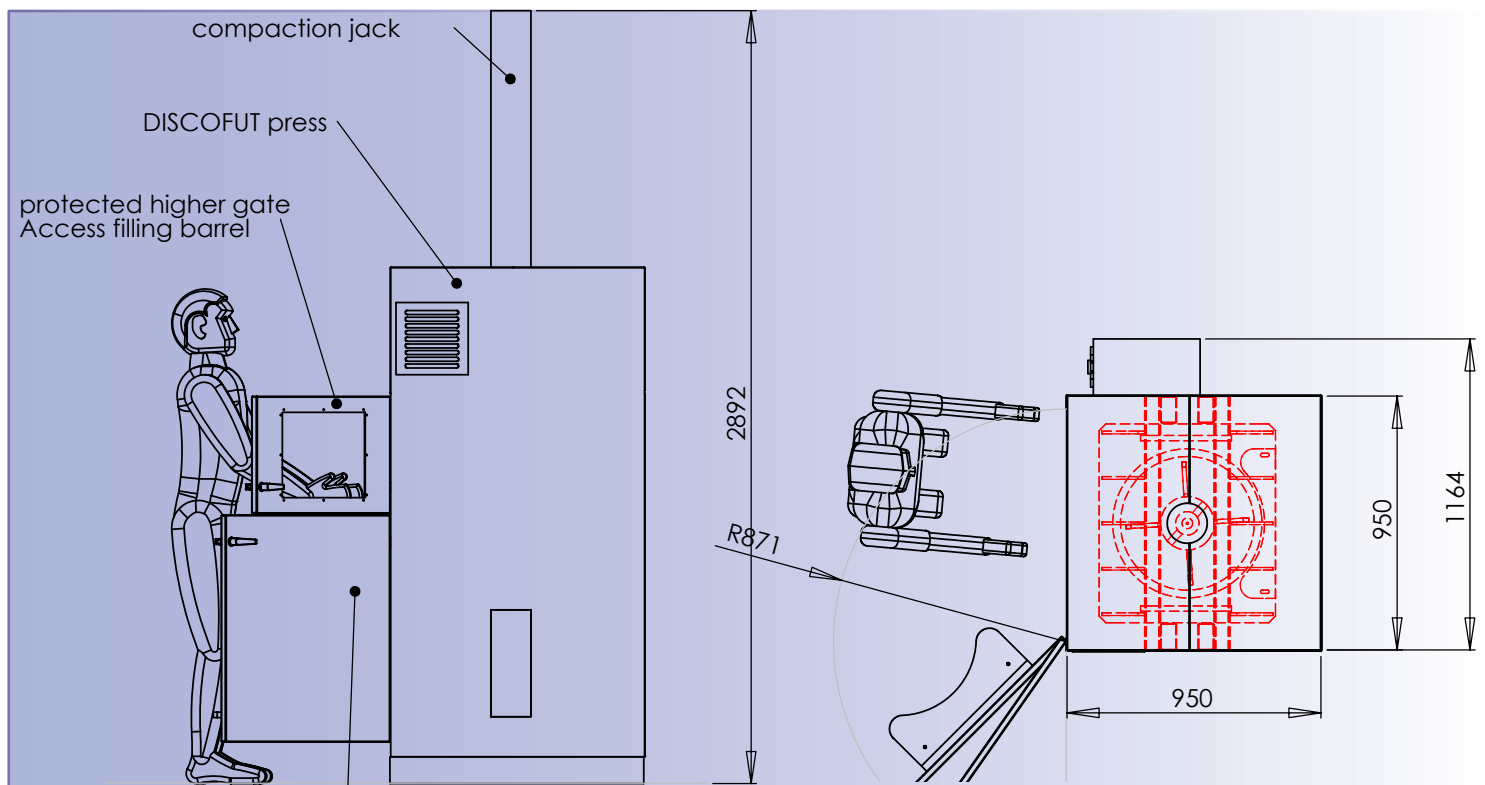

protected lower gate
Centering and immobilization of the barrel



electric control box

compaction plate

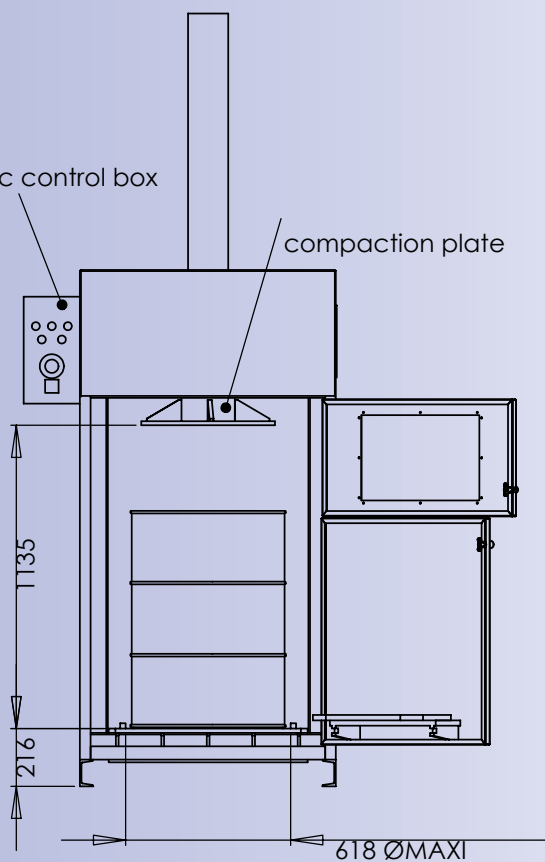

1- DISCOFUT Press

Plate in high position Open doors

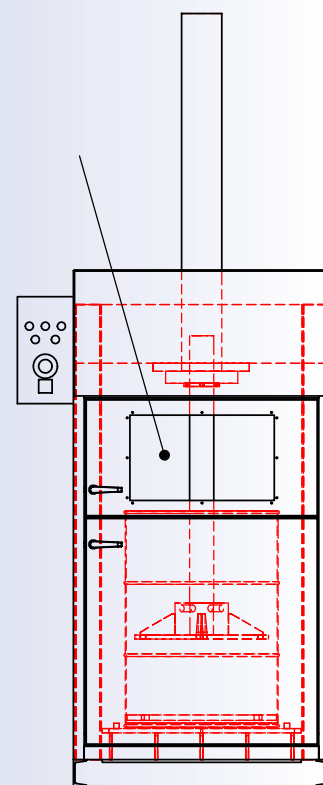

2- DISCOFUT Press

Plate in low position
closed doors